

Peppermint

The Samford Set – Pants

A sewing pattern from *Peppermint Magazine*, created in collaboration with:

SEW TO GROW[®]
with *Lindsey Rae*

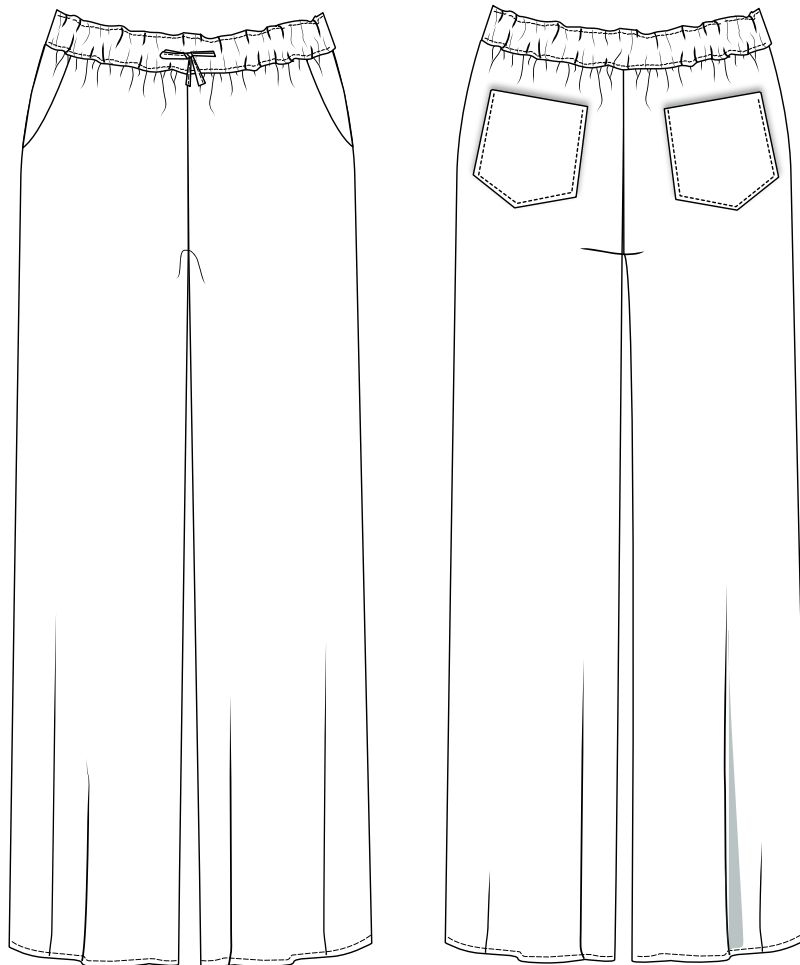

This pattern has been created in partnership with Spoonflower! The world's largest marketplace of independent designs from global artists, Spoonflower is leading the way in sustainable textile printing. Their on-demand process significantly reduces materials, energy and water, with inks that meet Oeko-Tex 100 requirements and fabrics – including a Certified Organic range – that are ethically sourced. Pop over to [spoonflower.com](https://www.spoonflower.com) for inspiration for your next me-made project!

FOR ALL OUR FREE SEWING PATTERNS HEAD TO [PEPPERMINTMAG.COM/SEWING-SCHOOL](https://www.peppermintmag.com/sewing-school)

Peppermint Patterns

SEWING PATTERN TERMS AND CONDITIONS

Thank you for downloading this pattern!
Here are a few T&Cs before you get started...

© Copyright of this pattern remains with *Peppermint Magazine*.

This pattern has been created for you to print and copy for individual home use only.

The pattern cannot be used for commercial purposes or to create and sell garments.

The pattern cannot be copied or distributed to others (physically or digitally).

If you'd like to feature the pattern on your website or social media (thank you!), we just ask that you please link to Peppermintmag.com and the patternmaker and that you do not upload the pattern or instructions.

The pattern can be used for non-commercial, non-paid community sewing groups, but not for ticketed and paid-for sewing workshops.

Please contact *Peppermint* if you'd like to find out about our licensing fee for workshops.

If you'd like to share your makes on social media, please tag us @PeppermintMagazine #PeppermintPatterns #PeppermintSamfordSet so we can see your handiwork!

GET IN TOUCH: sewing@peppermintmag.com

MORE FREE PATTERNS: peppermintmag.com/sewing-school

PATTERN INFORMATION

STYLE NOTES

The Samford Pants are the perfect blend of casual comfort and effortless style. Designed with the confident beginner in mind, this pattern features a wide elasticised waistband with front tie, back patch pockets and slanted front pockets. The elastic is sewn securely into place on top and bottom to prevent rolling or flipping and the added tie ensures that you can adjust the waist for your comfort. This pattern features two length variations: pants and shorts, allowing you to wear it throughout the changing seasons.

FIT OVERVIEW

The Samford Pants are designed to be loose fitting and drop straight from the thigh down creating a wide leg silhouette. The pants are drafted for someone that is 5'8" making the pants finished length 25" (63.5cm) and the shorts inseam 5" (12.7cm). The elastic waistband should sit comfortably just below your natural waist and can be adjusted to fit tighter or looser before securing the elastic.

CHOOSING YOUR SIZE

Start by measuring yourself and recording your measurements and the correlating size with the chart provided. Use your waist measurement to trace the waistband and if your hip measurement is more than 2 sizes out from your waist, then I would suggest grading from the top of the pant pattern out to your hip size using a French curve to blend between the sizes. The pants are quite generous through the thighs, so refer to the finished measurements if you prefer the pants to fit closer.

PATTERN HACK (OPTIONAL!)

To make this a super quick sew, skip making and attaching the back pockets, eliminate the tie and button holes on the waistband, and use the pocket back piece to draw in the rest of the side seam and waist on front pant to eliminate the front pockets as well.

SHORTEN/LENGTHEN

This pattern includes shorten and lengthen lines. The pattern is drafted for someone that is 5'8" (173cm) so you may choose to shorten or lengthen the pattern to suit your height. For decreasing length simply mark and fold up using the shorten line and to add length you will need to cut on the line and add in your desired length.

There is also a shorten and lengthen line in the crotch area of the pants. Everyone has a different girth and prefers to wear their pants sitting at different spots on their body. (Ex: waist, tummy, hips) This pattern is designed to sit just above your hip bones, but you can easily shorten or lengthen this area to have the Waistband sit where you like.

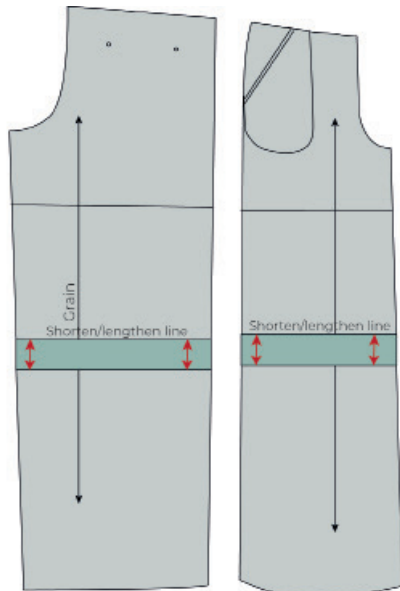

Add length evenly
Use grain line and cut line to keep
lines parallel

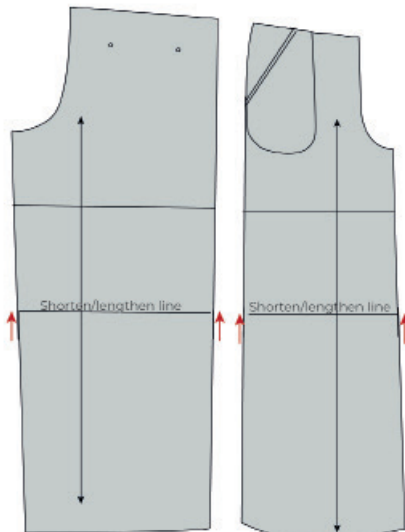

Shorten equally and evenly
Use the grain line. Check and true



MATERIALS REQUIRED

FABRIC

This pattern is best suited to light to medium weight woven fabrics. Try to steer clear of fabric that is too thin or light weight to avoid the Samford Set looking like bedtime pyjamas. Stick to linen and linen blends, cotton sateen, cotton lawn or a heavier weight rayon (Viscose).

INTERFACING

Small rectangle approximately 2" (5cm) X 3" (7.5cm) of tear away interfacing.

NOTIONS

- 2" (5cm) Elastic (Use provided elastic chart for length)
- Thread

Optional Tools

- Buttonhole Punch/Blade - Tool with sharp blade at the end to open buttonhole with.
- Bodkin or Safety Pin to help pull elastic through waistband.
- Scissors
- Thread Snips
- Iron

FABRIC REQUIREMENTS

		TOP		SHORTS		PANTS	
		METERS	YARDS	METERS	YARDS	METERS	YARDS
SIZES A-H	140CM	1.5	1.65	1.5	1.9	2.6	2.85
	113CM	1.6	1.75	1.8	2	3	3.3
SIZES I-P	140CM	1.7	1.9	2.1	2.3	3	3.3
	113CM	2	2.2	2.1	2.3	3.7	4

PEPPERMINT SIZE CHART: BODY MEASUREMENTS

		A	B	C	D	E	F	G	H	I	J	K	L	M	N	O	P
BUST	CM	81	83	86	89	91	94	99	104	109	114	119	124	129	134	139	144
	INCHES	32	33	34	35	36	37.5	39	41	43	45	47	49	51	53	55	57
WAIST	CM	64	66	69	72	74	77	82	87	92	97	102	107	112	117	122	127
	INCHES	25	26	27	28	29	30.5	32	34	36	38	40	42	44	46	48	50
HIP	CM	89	93	95	98	100	103	108	113	118	123	128	133	138	143	148	153
	INCHES	35	36	37	38	39	40.5	42	44	46	48	50	52	54	56	58	60

SIZE CHART: PANTS FINISHED MEASUREMENTS

		A	B	C	D	E	F	G	H	I	J	K	L	M	N	O	P
WAIST	CM	66	69	72	74	76	79	82	84	89	94	100	105	110	115	120	125
	INCHES	26	27	28	29	30	31	32	33	35	37	39	41	43	45	47	49
HIPS	CM	104	108	112	116	120	125	130	135	140	145	150	155	160	165	170	175
	INCHES	41	42.5	44	45.5	47	49.5	51	52.5	55	57	59	61	63	65	67	69

ELASTIC CUTTING GUIDE MEASUREMENTS

		A	B	C	D	E	F	G	H	I	J	K	L	M	N	O	P
ELASTIC	CM	77	78	80	81	82	84	86	89	91	93	96	99	101	104	107	109
	INCHES	30	31	31.5	32	32.5	33	34	35	36	36.5	37.5	39	40	41	42	43

GLOSSARY

RST and WST

RST refers to right sides together. This is the side of the fabric that shows on the outside of the garment. WST refers to wrong sides together. This is the back or inside of the fabric

BASTE

Set your machine to a slightly longer stitch (4-5 stitch length) and stitch inside the seam allowance to tack and hold layers together.

UNDERSTITCH

Understitching is when you sew the seam allowance to the facing to help keep the garment laying flat and prevent rolling.

TOPSTITCH

A topstitch is a stitch that is sewn to the outside of the garment, typically close to an already sewn edge, to sew layers together and hold everything in place. This stitch will be seen so it is important to sew straight using a guide (like an edge stitch foot) and to ensure you thread colour matches.

OVERLOCK/SERGE/ ZIG-ZAG

After a seam is sewn, you may wish to overlock or zig zag the raw edges of your fabric to prevent fraying of your garment. If you don't own an overlocker/serger, I would suggest using a machine stitch that looks similar to the ones below. I will mention when to use these stitches within the instructions. The term used throughout the pattern will be 'overlock'.

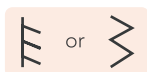

PRINTING AND TRACING

PRINTING THE PDF PATTERN

Only print the size(s) you need from the PDF thanks to the layer functionality in Adobe Acrobat Reader, allowing you to select the required size(s). Always keep the “Text” and “Format” layers. In A4, there are 24 pages (for sizes A to F) or 28 pages (for sizes G to M) to print. In Ao, there are 2 pages to print.

A4 pattern

Assemble the pages together with magic tape.

Make sure your printing settings are set up at 100% scale.

Ao pattern

Contact your local print or copy shop for large scale printing.

CUTTING TIPS

Paper cutting - cut all the pattern pieces according to your size and pattern adaptations with paper scissors.

Fabric cutting - pin each pattern piece on the fabric following the cutting layout set out on the next page, and cut each piece close to the paper with fabric scissors or a rotary cutter.

CUTTING LAYOUTS

TRACE

The pattern pieces included are full size pieces with seam allowances already included. To preserve the integrity of your pattern, trace pattern pieces onto preferred tracing paper. Make sure to transfer the size, name of pattern, and markings. Once traced, cut out the pattern pieces in your size.

CUT FABRIC

Before you begin, pre-wash and care for your fabric to prevent unwanted shrinkage. I also suggest making a sample (muslin) to check sizing, fitting, and length. Use the shorten/lengthen line to change length if desired. Fold your fabric in half Right Sides Together with selvage edges matching. Place your pattern pieces onto the fabric as shown in the relevant diagrams below.

CUTTING LAYOUTS



140 CM Fabric Up to Size H

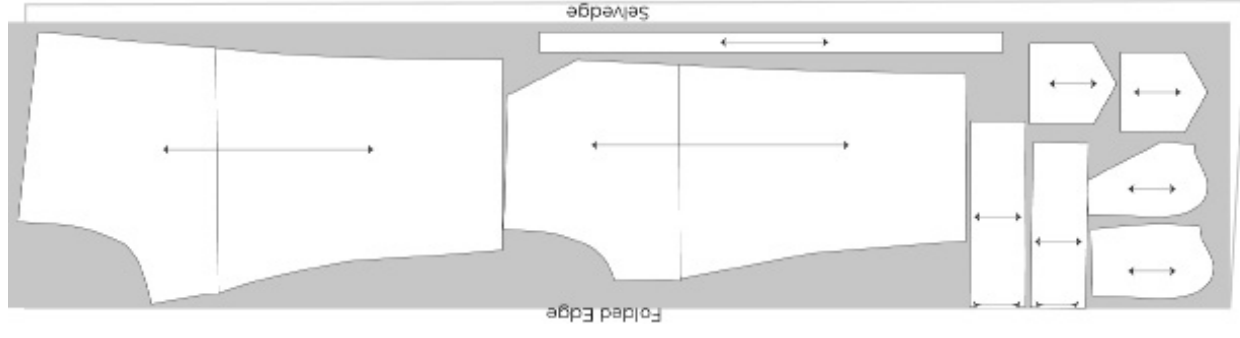

140 CM Fabric Sizes I - P

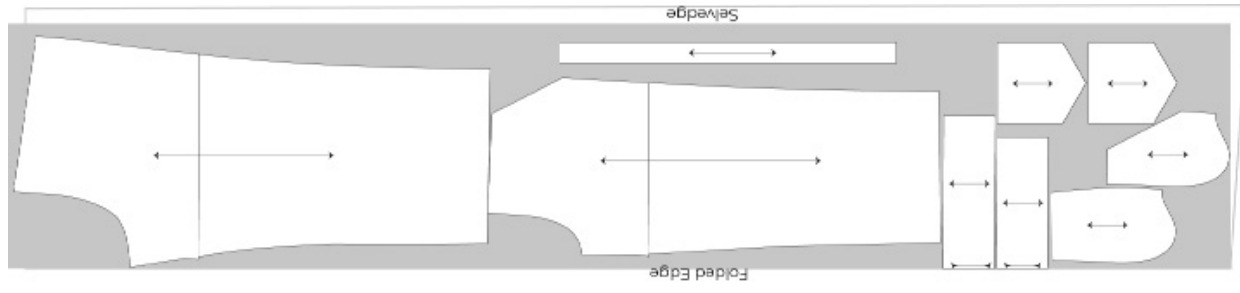

113 CM Fabric Up to Size H

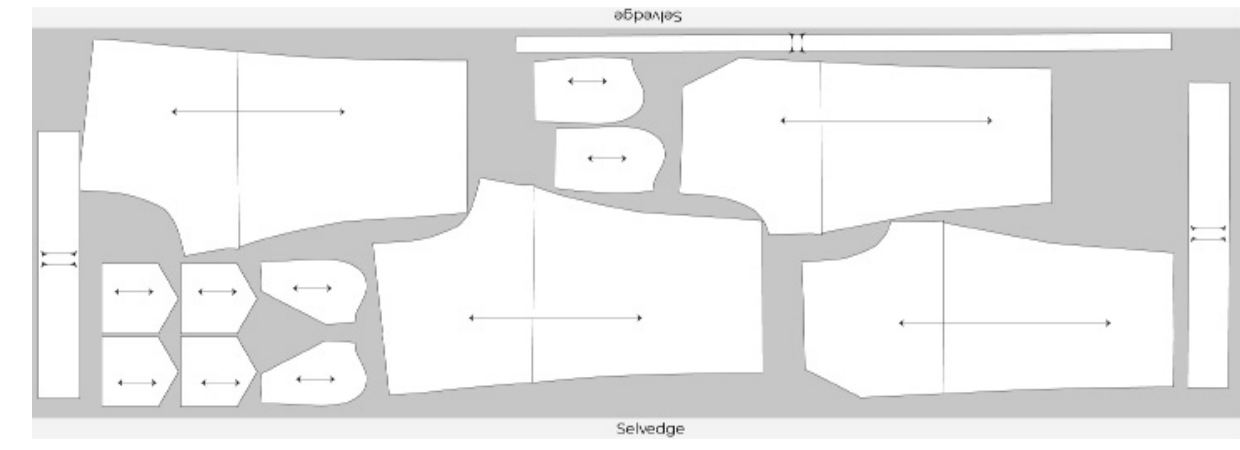

113 CM Fabric Sizes I - P

CUTTING LAYOUTS



113 CM Fabric Sizes I - P

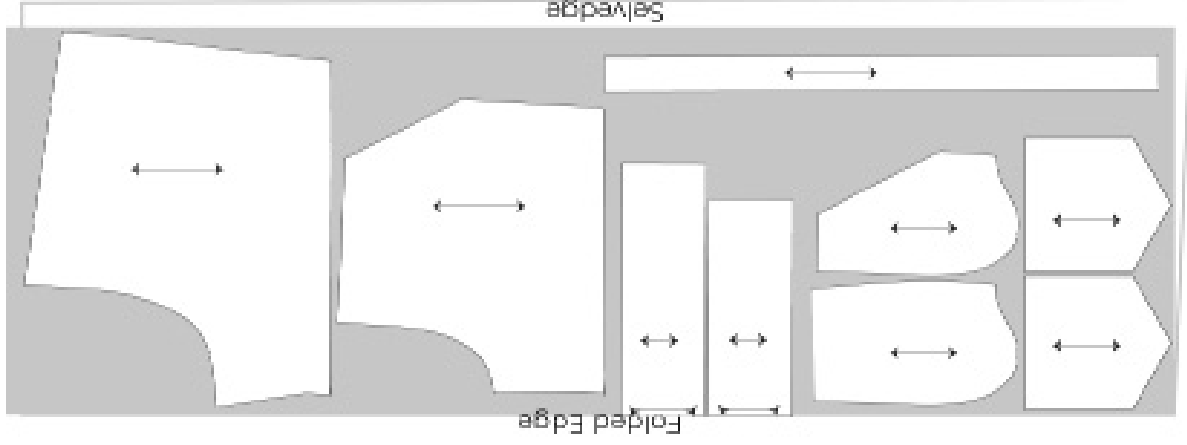

113 CM Fabric Up to Size H

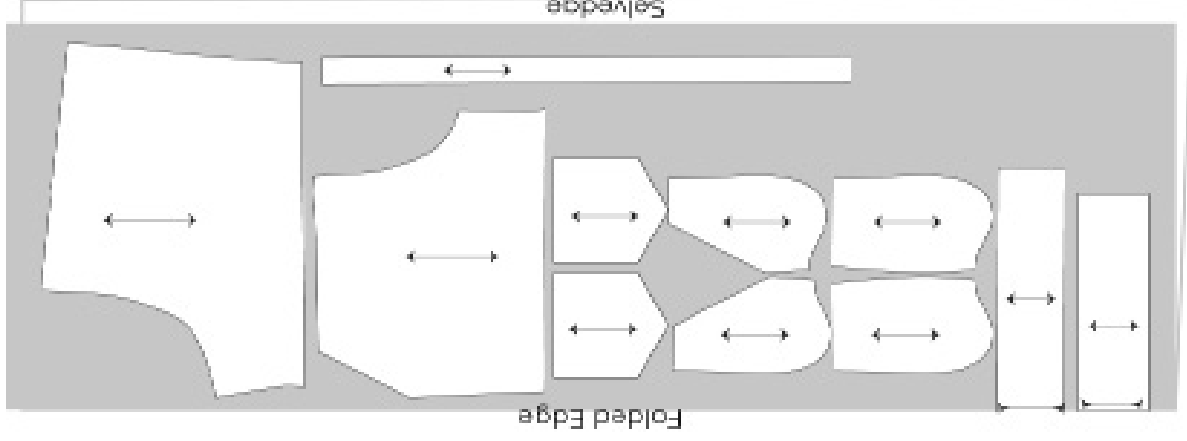

140 CM Fabric Size I - P

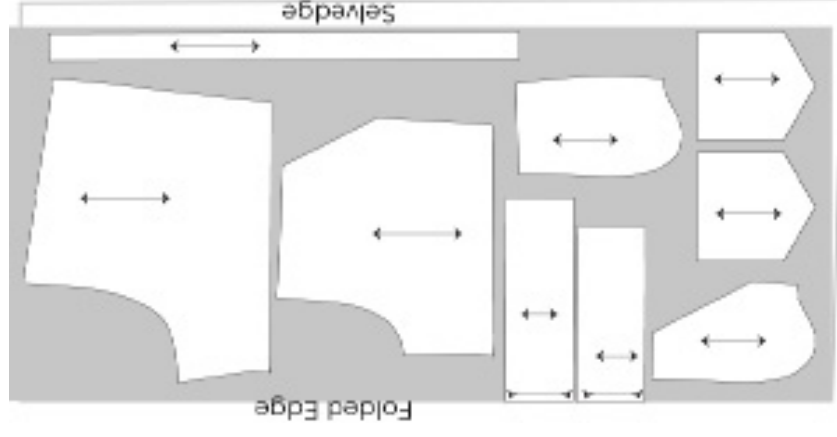

140 CM Fabric Up to Size H

SEWING INSTRUCTIONS

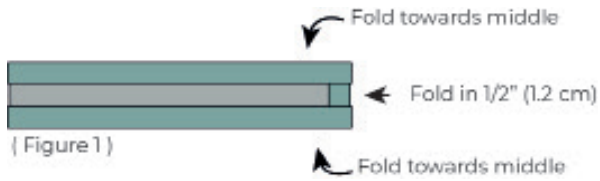

Thread your machine with coordinating thread, insert a new needle, and set your machine for a straight stitch. All seams are 3/8" (10mm) unless otherwise stated.

MAKE DRAWSTRING

1. Make Drawstring

Start by sewing the two tie pieces end to end RST to create one long tie. Press seam allowance open.

Next, fold and press in both short ends 1/2" (1.2cm).

Then fold long edges in towards middle and press.

(Figure 1)

Finally, press the drawstring in half (matching the folded edges) and sew 1/8" (3mm) close to the folded edge, as shown. (Figure 2)

Once made, set aside for now.

POCKETS

2. Make Back Pockets

Place Back Pocket pieces RST. Sew around all four sides, pivoting at the corners and leave a 2" (5cm) opening at the side. (Figure 3)

Clip corners, as shown, and turn pocket right side out through the hole. (Figure 4)

Poke out corners and press pocket, making sure to press in the edges of the hole. (Figure 5)

3. Attach Pockets to Back

Place Back Pocket on Back Pants, lining up with the pocket markings for your size.

Pin and topstitch close to outside edges leaving the top open. Make sure you secure with a backstitch at the beginning and end. (Figure 6) Repeat for other back pocket.

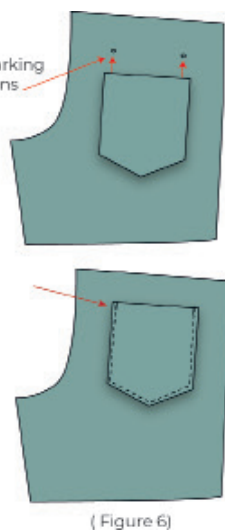
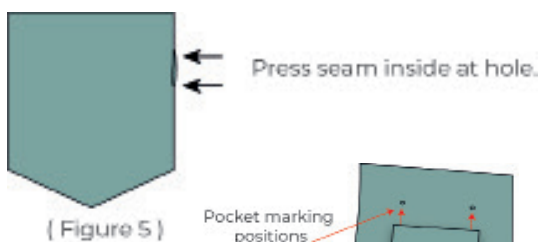
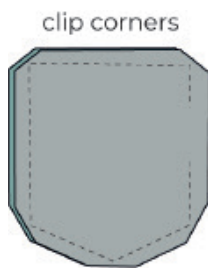
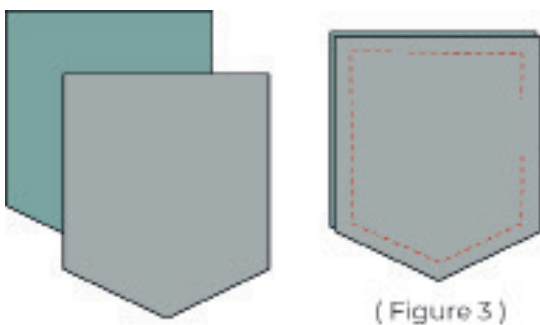
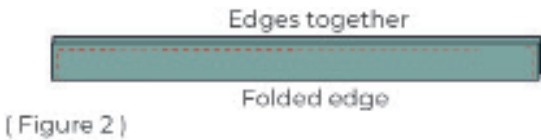

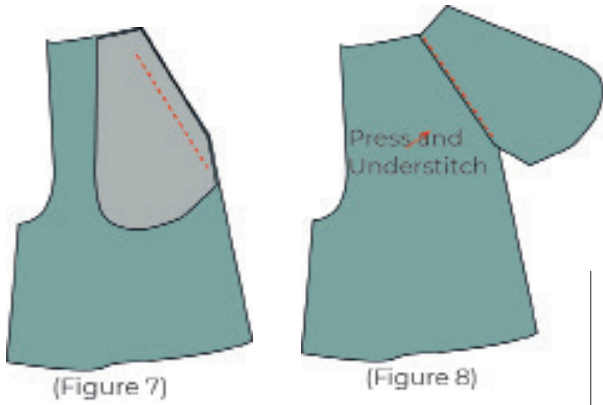

4. Attach Front Pockets

Place Pocket fFront RST with corresponding edge on Pants Front piece at the pocket seam. Stitch in place, as shown. (Figure 7)

Press pocket and seam allowance away from Pants Front. Understitch pocket piece close to seam. (Figure 8)

Next, align outside edges of Pocket Front and Pocket Bag RST. Sew around outside edge only. Overlock once sewn. (Figure 9)

Flip pocket to wrong side of Pants Front, aligning the top and side edges. (the pocket bag should complete the waist and side seams.) Press. Baste with a 3/16" (5mm) seam allowance along the top and side to hold the pocket in place (Figure 10). Repeat these steps for the opposite leg.

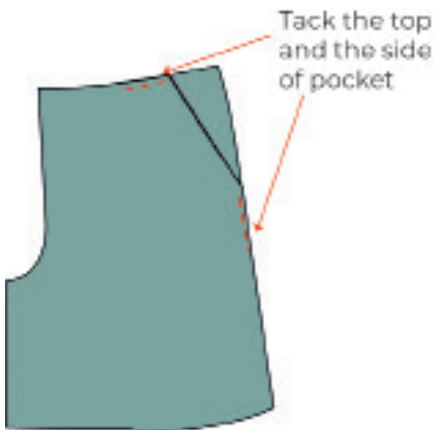
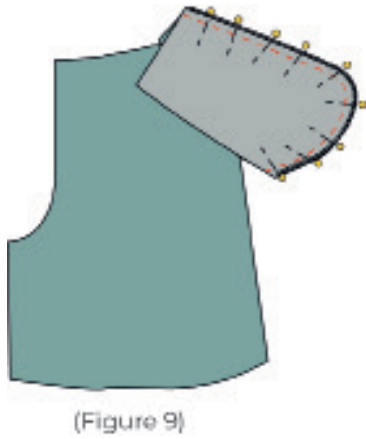

5. Sew Side and Leg Seams

Place Pants Front and Back RST at side seams. Sew and overlock. Press seams to the back. Repeat for opposite leg. (Figure 11)

Next, match front and back inseam RST. Sew and overlock. (Figure 12)

Press one seam toward the back and one toward the front. Repeat for opposite leg before ironing. You should now have two separate legs.

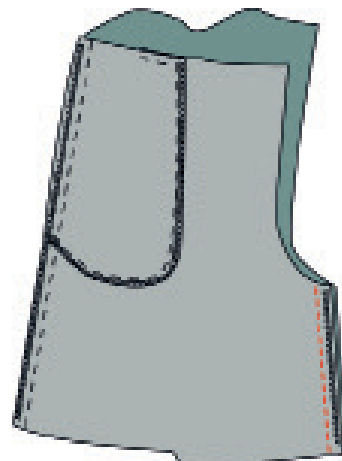
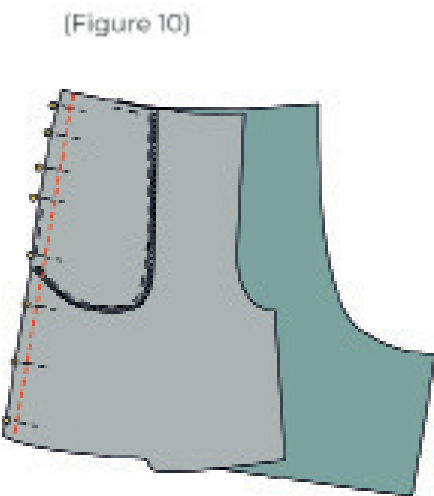

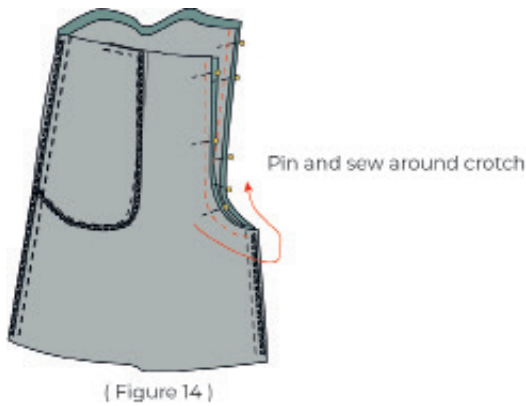
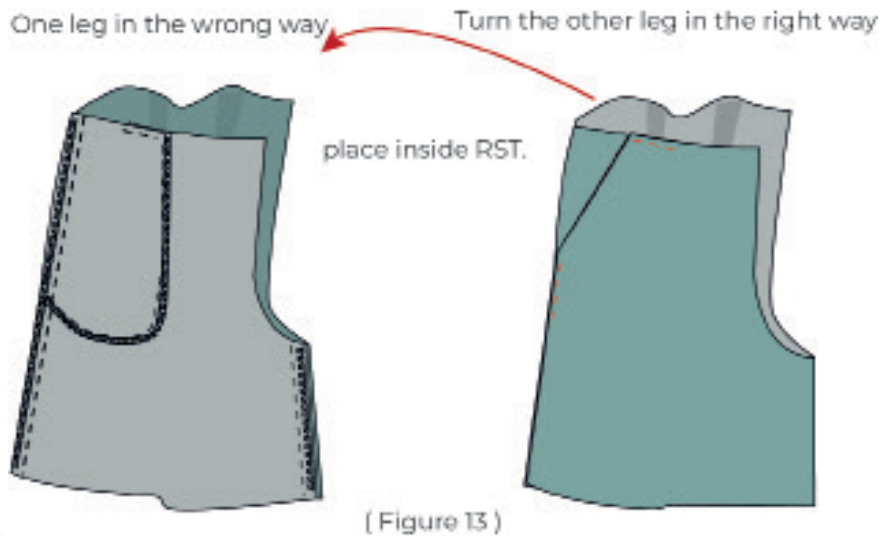

6. Sew Crotch Seam

Turn one leg RIGHT SIDE OUT (Figure 13)

Next, place that leg INSIDE the other leg, matching RST at the crotch seam. Both Pants Fronts and Backs should be lined up. Pin and sew around the U-shape. Overlock once sewn. (Figure 14)

Flip pants right side out.

MAKE AND ATTACH WAISTBAND

7. Attach Interfacing

Start by placing a small rectangle of tear-away interfacing on the wrong side of the fabric behind button hole markings on Front Waistband. (Figure 15)

Pin from the front to secure interfacing. (Figure 16)

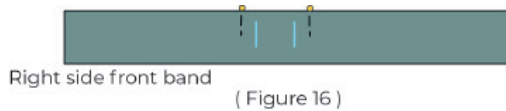
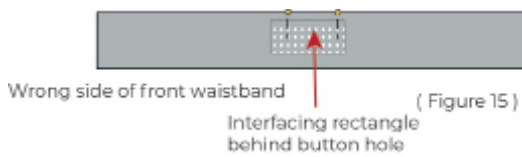

8. Sew Buttonholes

Set your buttonhole foot/machine to sew a 7/8" (2.2cm) buttonhole. Test buttonholes on a scrap first to test size and density before sewing on your garment.

Once you are confident with how the buttonhole looks, sew the two buttonholes onto Front Waistband. After the button hole is sewn use scissors, seam ripper or a buttonhole cutter to open. (Figure 17)

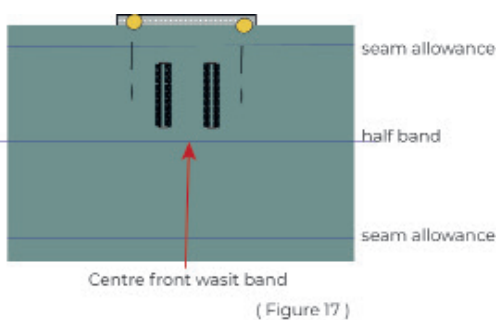

9. Sew Waistband

Place Front Waistband RST with Back Waistband matching side seams. (the Back piece will be much longer). Pin and sew side seams, as shown. (Figure 18)

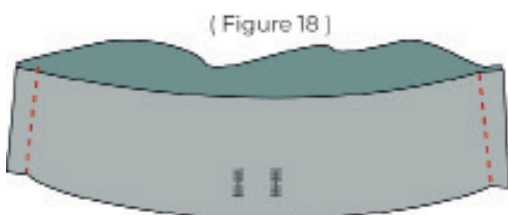

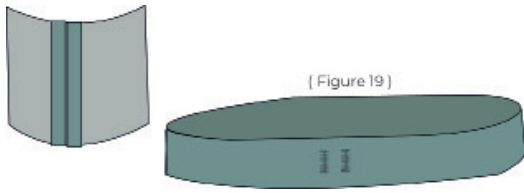

(Figure 19)

Press side seam allowances open.

Next, press waistband in half, wrong sides together, matching raw edges along the bottom. (Figure 19)

10. Attach Waistband

Pin waistband onto the top of your pants with raw edges matching, aligning the side seams together and the buttonholes facing RST and centred with the centre front seam of the pants (Figure 20)

Pin and sew around the top edges leaving a 2" (5cm) gap at the centre back. (Figure 21)

INSERT AND SECURE ELASTIC

11. Insert Elastic

Cut elastic to length using the provided cutting guide.

Insert the elastic through the opening in the waistband, at the back, using a bodkin or safety pin. Pull and push elastic through until you reach the other side of the opening. (Figure 22)

Tip: Secure end of elastic with a pin to the pants so that you don't accidentally lose it through the waistband

12. Secure and Close Hole

Pull through the elastic and overlap ends by 1" (2.5cm) Secure with a pin and try on to determine if you would like the elastic tighter or looser. Once you are happy with the fit sew a rectangular box to secure the elastic ends together. (Figure 23)

Next, pull fabric back into waistband and close 2" (5cm) gap at the back. Once sewn, overlock raw edges and press seam allowance down toward pants. (Figure 24)

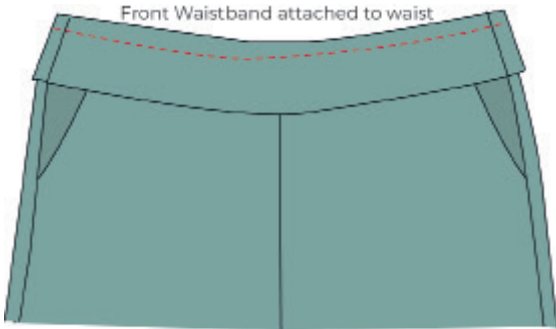

(Figure 20)

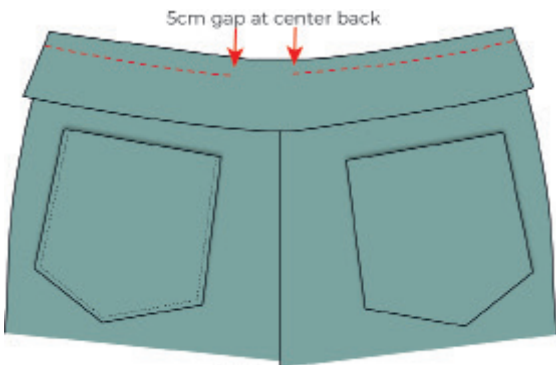

(Figure 21)



(Figure 22)

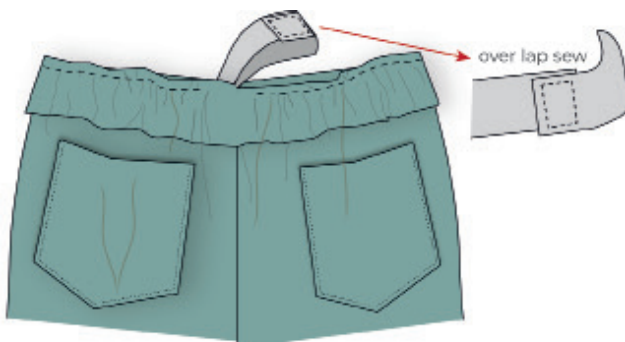

(Figure 23)

Elastic inside and opening sealed and overcast edge



(Figure 24)

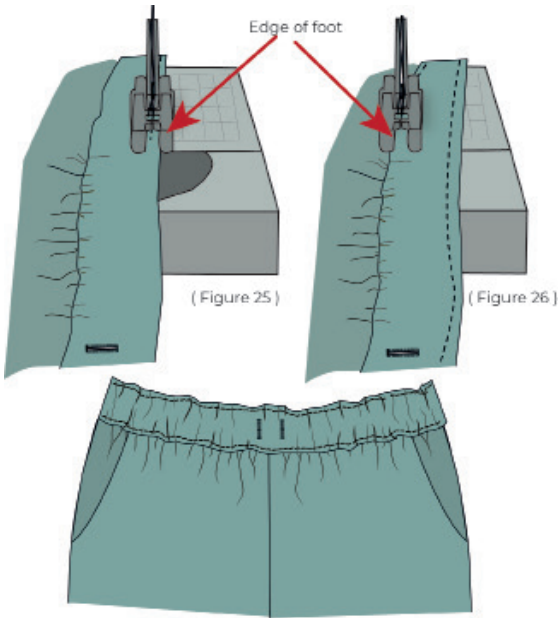

13. Secure Elastic to Waistband

This step is optional, but helps to secure the elastic inside the waistband and prevent rolling.

Using the edge of your foot as a guide, sew 1/4" (6mm) from top edge of waistband. As you sew, pull the waistband and elastic completely straight as you feed it under the foot. You will be pulling slightly from the back as you sew and guiding from the front. The trick to consistent stitches is to allow the feed dogs to do the work and not pull from the back too quickly. Sew small sections at a time. Pull straight, sew, reset. (Figure 25)

Repeat same technique and sew 1/4" (6mm) up from bottom edge of waistband. (Figure 26)

HEM AND INSERT DRAWSTRING

14. Insert Drawstring

Using a safety pin or bodkin, feed the drawstring made in Step 1 through buttonhole openings. Tie in a bow once it is threaded all the way through to the other side. (Figure 27)

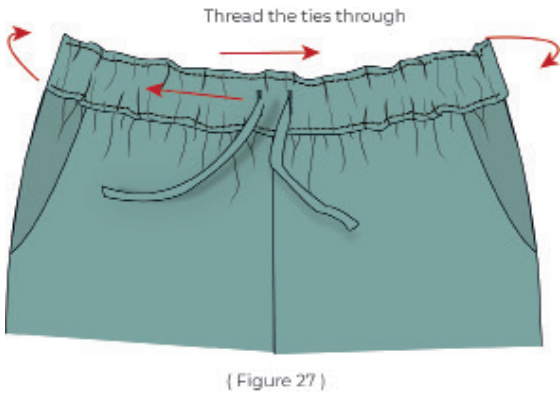

15. Hem

Mark and press up bottom edges of pants twice at 1/2" (1.2cm). (Figure 28)

Topstitch close to inside folded edge. Repeat for opposite leg. (Figure 29)

Finish and enjoy!

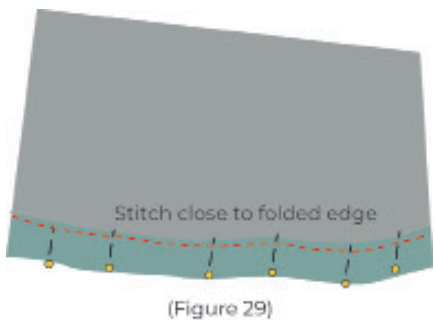
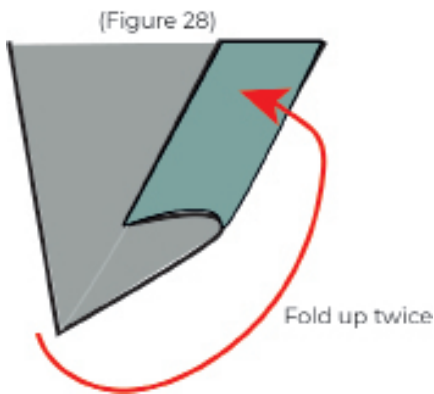

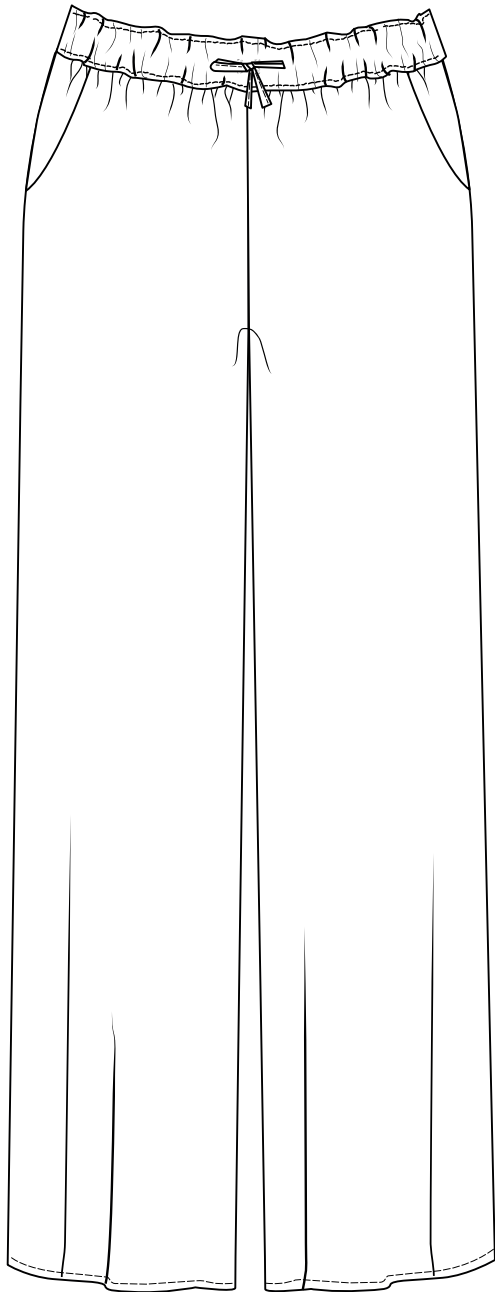

The Peppermint Samford Set was created in collaboration
with Lindsey Rae from Sew to Grow!
Find out more at sewtogrow.com.au